

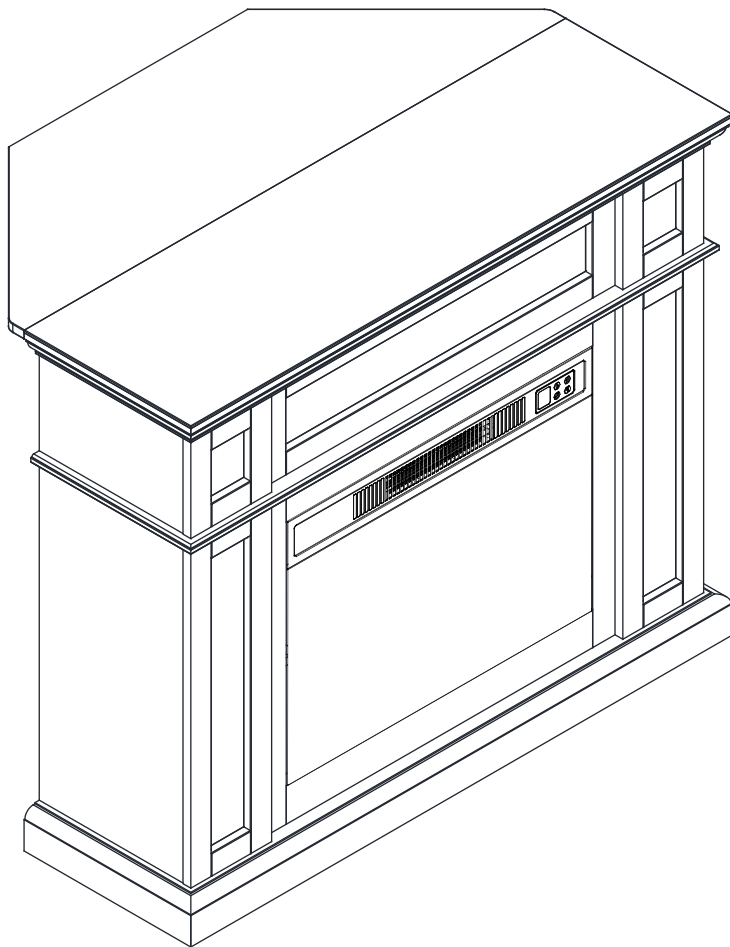

ArtiFlame

IMPRESSIVE LOOK OF YOUR ROOM



LINZ UNIVERSAL 2IN1

(EN) Electric fireplace mantel
(PL) Obudowa kominka elektrycznego
(DE) Rahmen für elektrischen Kamin
(UK) Портал для електричного каміна

Assembly instructions
Instrukcje składania
Montageanleitung
Інструкція зі складання

1. Follow the assembly instructions carefully.
2. Ensure that all parts are available.
3. To prevent damage, assemble the mantel on the carton.
4. Leave fasteners loose at each step of assembly, adjust screws to ensure a good fit, tighten all fasteners from all steps at the very end of assembly.
5. Clean the surface of the mantel with a damp cloth only, do not use abrasive cleaners.

1. Postępuj dokładnie według instrukcji składania.
2. Upewnić się, że wszystkie części są dostępne.
3. Aby zapobiec uszkodzeniom, składaj obudowę na kartonie.
4. Na każdym kroku składania pozostawić luźne łączniki, wyregulować śruby, aby zapewnić dobre dopasowanie, na samym końcu składania dokręcić wszystkie łączniki ze wszystkich kroków.
5. Czyść powierzchnię obudowy tylko wilgotną szmatką, nie używaj ściernych środków czyszczących.

1. Befolgen Sie sorgfältig die Montageanleitung.
2. Vergewissern Sie sich, dass alle Teile vorhanden sind.
3. Um Beschädigungen zu vermeiden, montieren Sie den Kaminrahmen auf dem Karton.
4. Lassen Sie die Befestigungselemente bei jedem Montageschritt locker, passen Sie die Schrauben an, um einen guten Sitz zu gewährleisten, ziehen Sie alle Befestigungselemente aller Schritte am Ende der Montage fest.
5. Reinigen Sie die Oberfläche der Kaminrahmen nur mit einem feuchten Tuch, verwenden Sie keine scheuernden Reinigungsmittel.







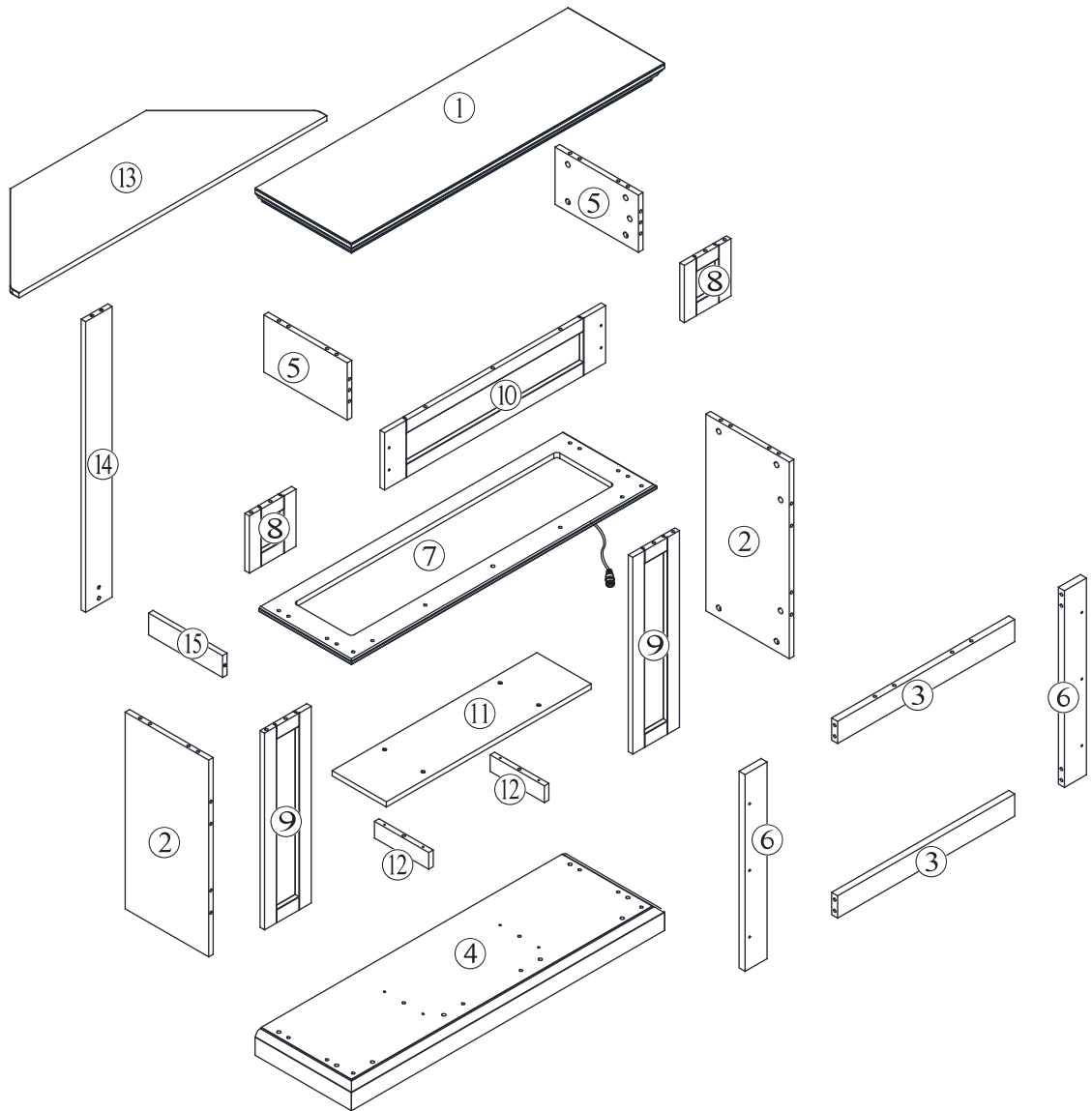



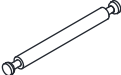

1. Ретельно дотримуйтесь інструкції зі складання.
2. Перевірте наявність усіх деталей.
3. Для запобігання пошкоджень, складайте портал на картонній коробці.
4. Залишайте кріплення послабленими на кожному кроці складання, відрегулюйте гвинти, аби забезпечити належне прилягання, затягніть всі кріплення з усіх кроків наприкінці складання.
5. Витирайте поверхню portalу тільки вологою ганчіркою, не використовуйте абразивні чистячі засоби.

Parts list / Lista części / Liste der Einzelteile / Перелік деталей

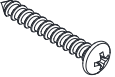
- ① x 1
- ② x 2
- ③ x 2
- ④ x 1
- ⑤ x 2
- ⑥ x 2
- ⑦ x 1
- ⑧ x 2
- ⑨ x 2
- ⑩ x 1
- ⑪ x 1
- ⑫ x 2
- ⑬ x 1
- ⑭ x 1
- ⑮ x 1

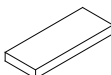
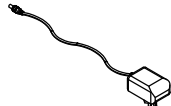
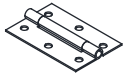

Fastenings / Elementy mocowania / Befestigungen / Кріплення

- | | | | | | | |
|---|---|---|---|--|---|---|
|  |  |  |  |  |  |  |
| Φ7.8 x 30 mm
A x 42 | Φ7.8 x 50 mm
B x 6 | C x 27 | D x 39 | E x 6 | F x 2 | Φ3.8 x 40 mm
G x 2 |
|  |  |  |  |  |  |  |
| Φ4 x 30 mm
H x 8 | Φ4 x 25 mm
I x 12 | J x 4 | K x 2 | L x 11 | M x 1 | N x 3 |
|  |  | | | | | |
| Φ4 X 14 mm
O x 18 | Φ4 X 10 mm *
CC x 4 | | | | | |

* packaged with a fireplace / w zestawie z kominkiem / verpackt mit einem Kamin / у комплекті з каміном

Necessary tools / Potrzebne narzędzia / Erforderliche
Werkzeuge / Необхідні інструменти

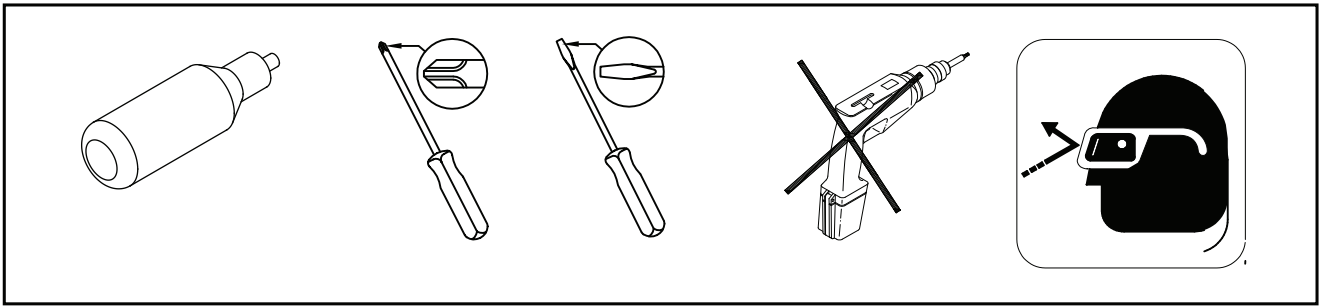

It is recommended to apply some glue into holes before inserting wood dowels. Glue is not enclosed.

Zaleca się, aby przed włożeniem drewnianych kołków do otworów włożyć trochę kleju. Klej nie jest zawarty w dostawie.

Es wird empfohlen, vor dem Einsetzen der Holzdübel etwas Kleber in die Löcher zu geben. Kleber ist nicht im Lieferumfang enthalten.

Рекомендовано нанести трохи клею в отвори перед вставлянням дерев'яних дюбелів. Клей не входить в комплект поставки.

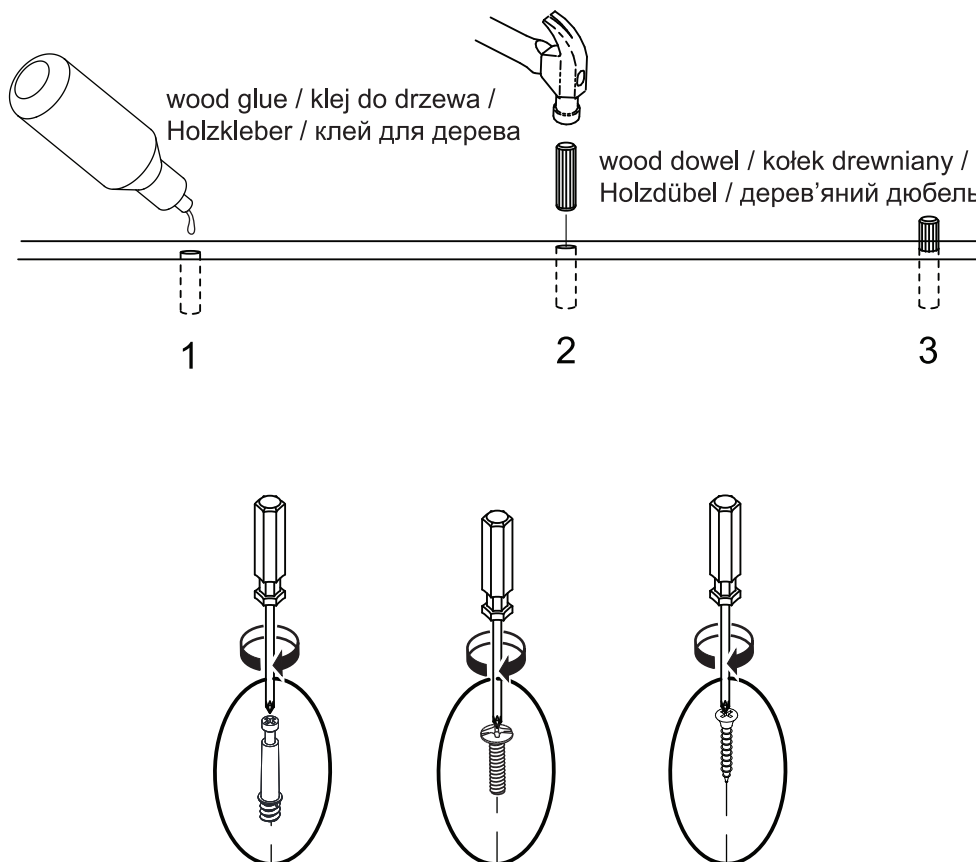

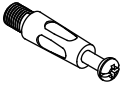

C x 8

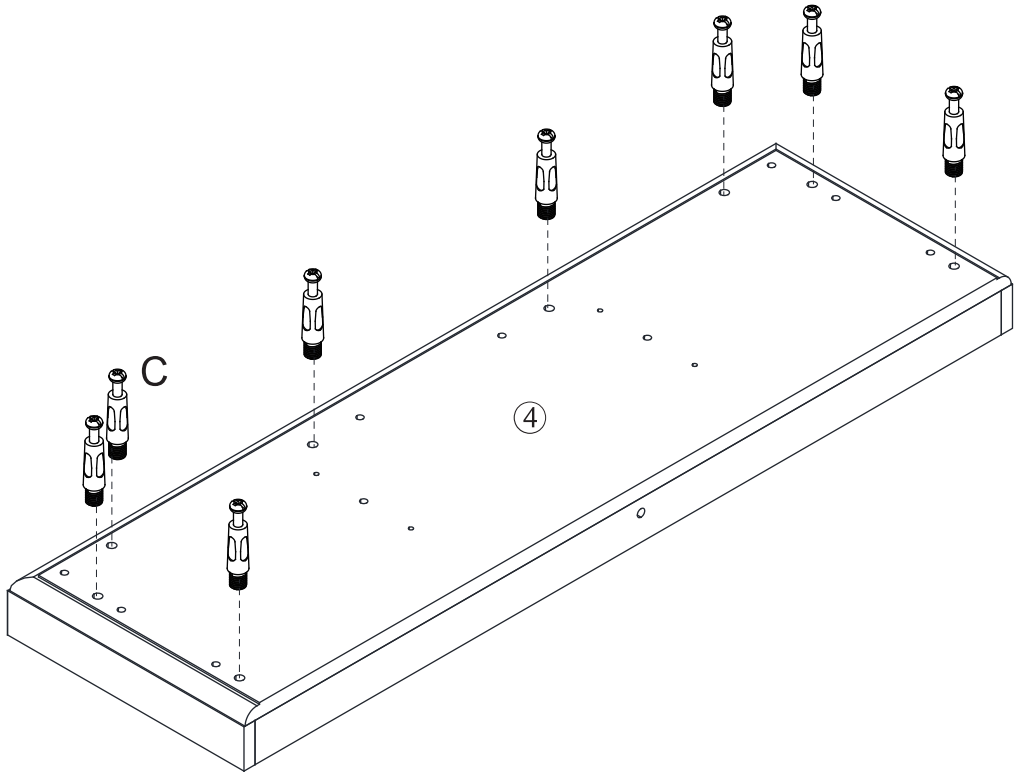



A x 4

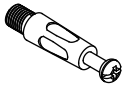

C x 4



D x 4

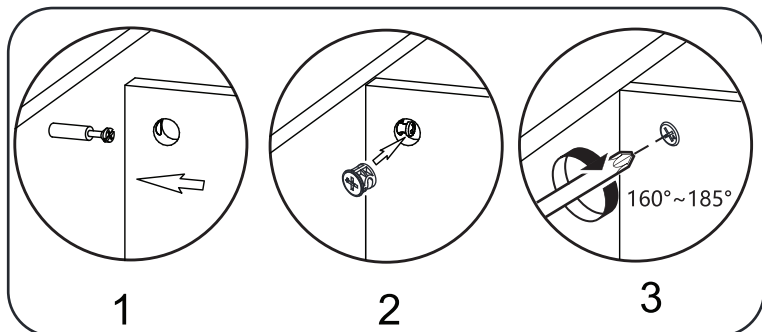
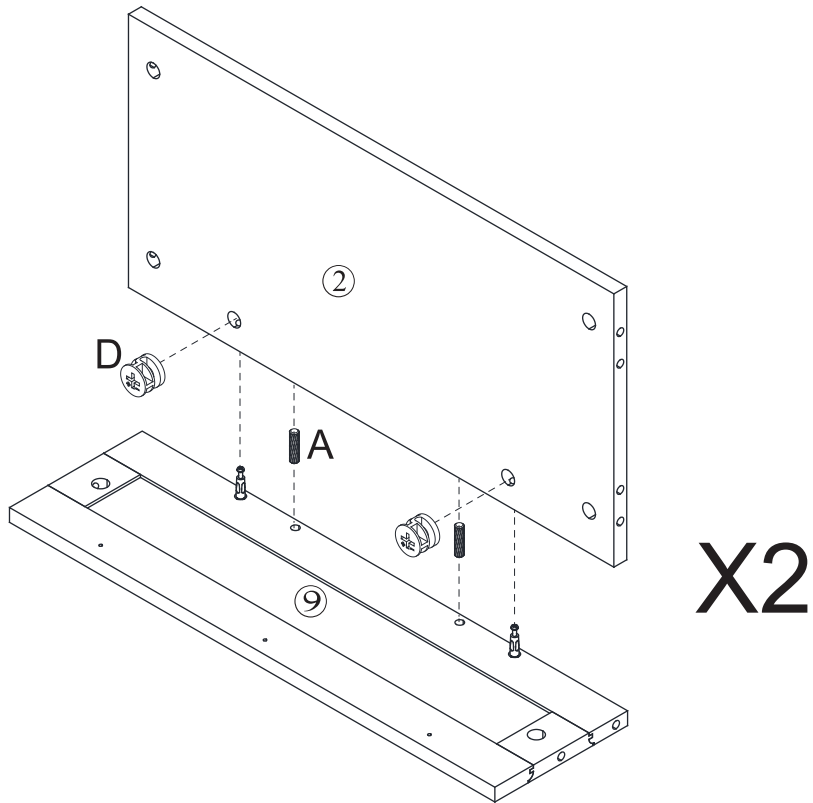
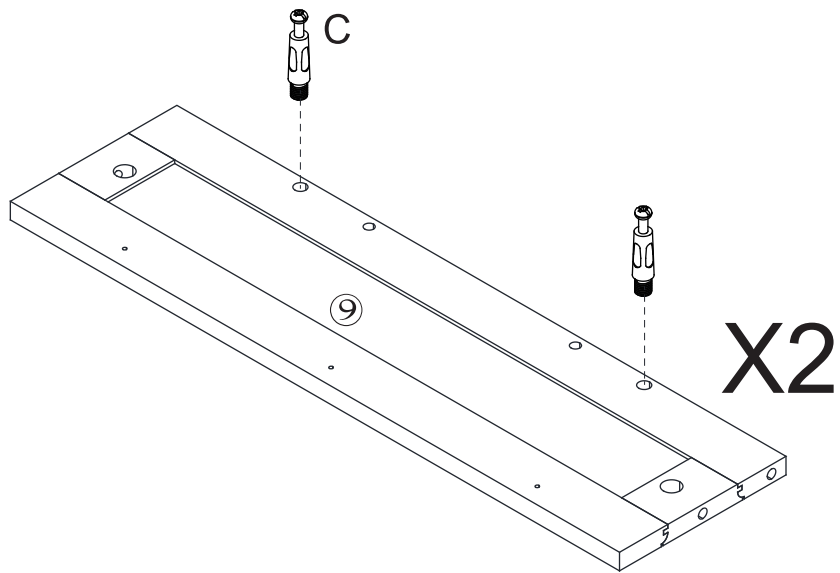



A x 6



D x 6

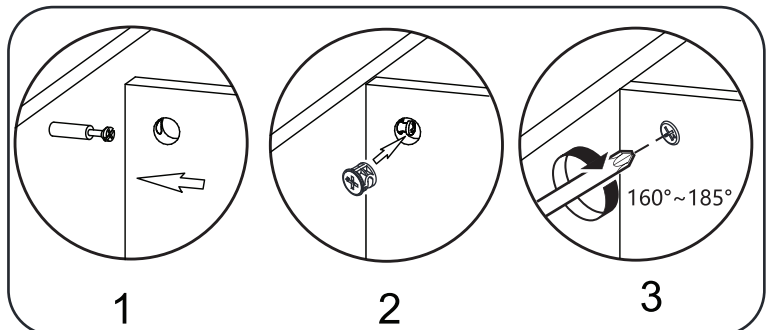
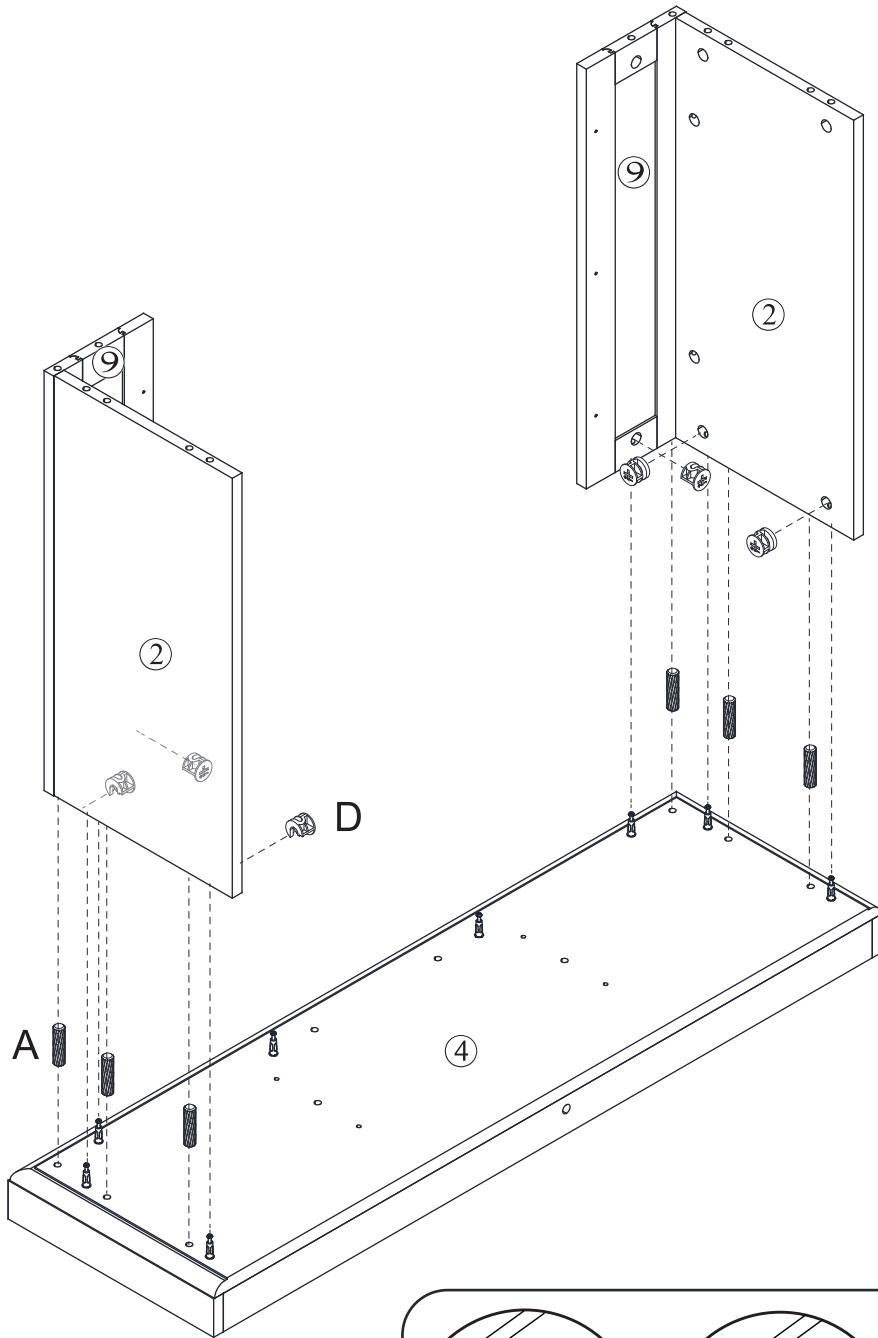



A x 10



D x 2

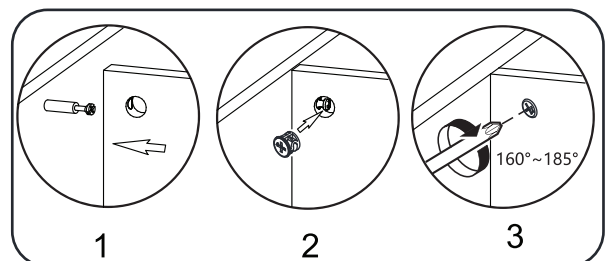
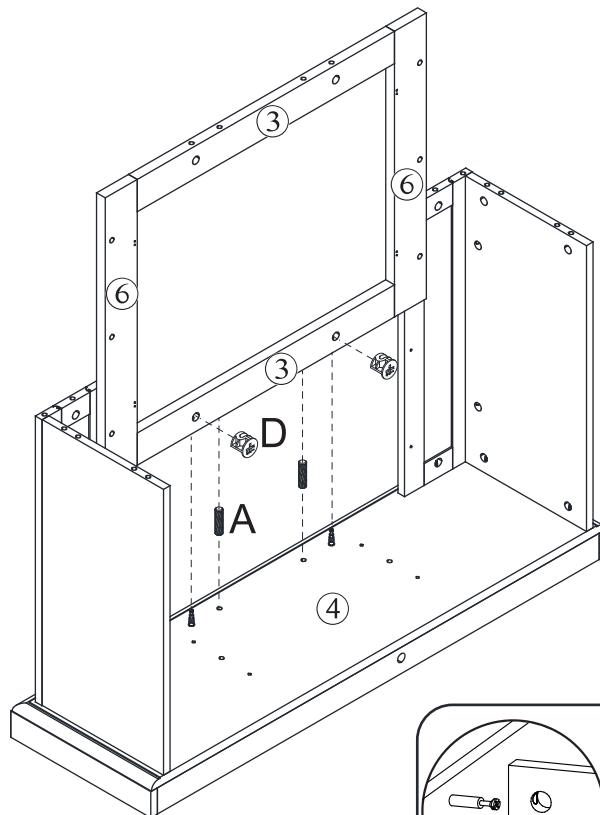
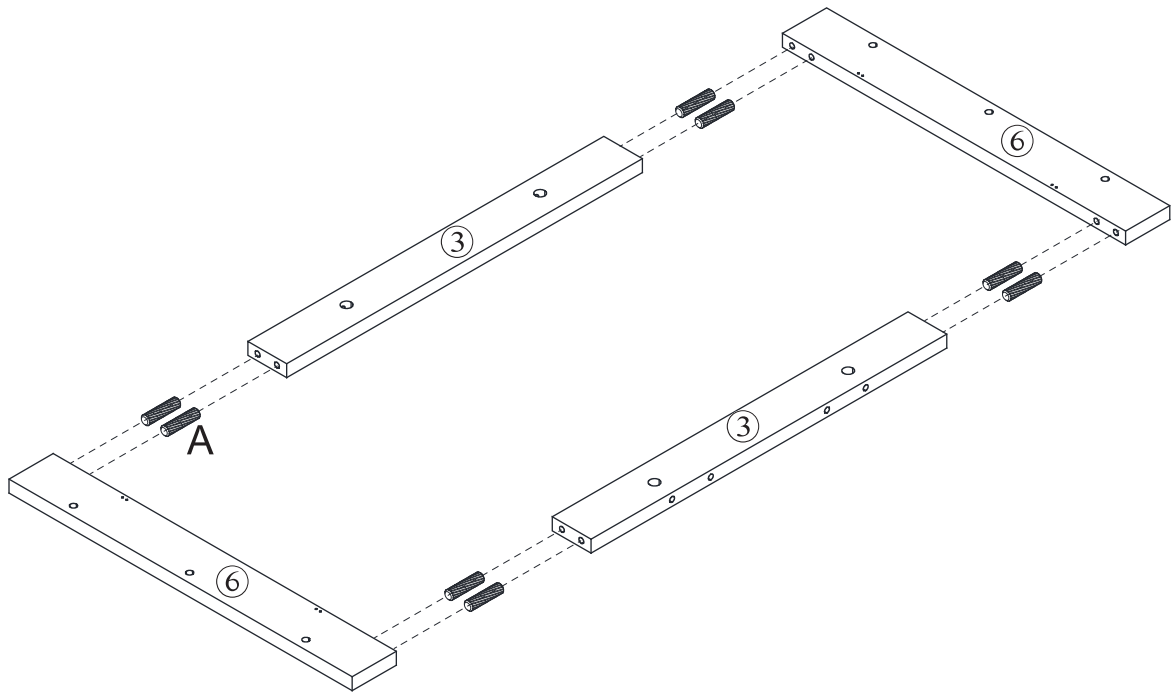

Step 5 / Krok 5 / Schritt 5 / Крок 5



B x 6



D x 6

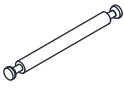

E x 6

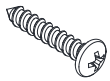

I x 6

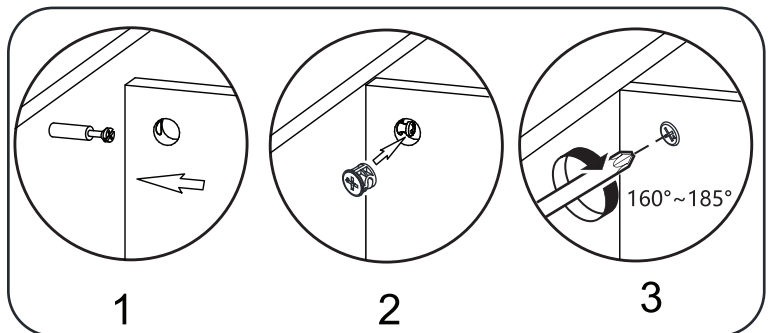
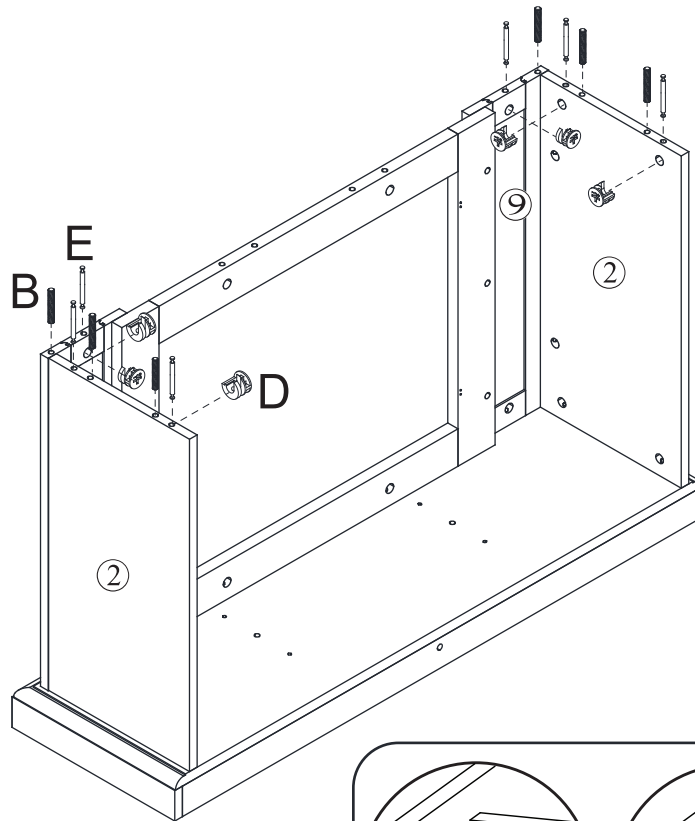
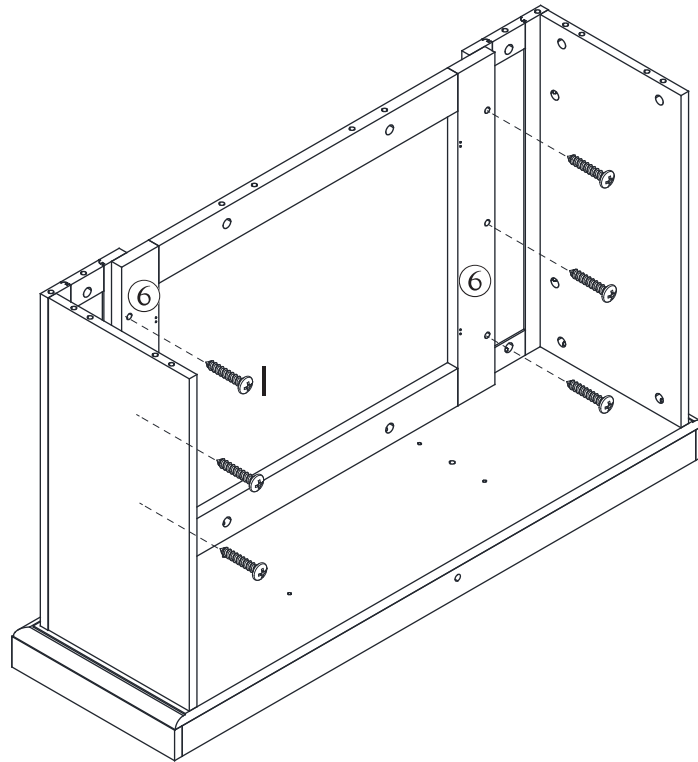



A x 2

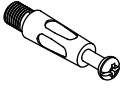

C x 3



D x 2

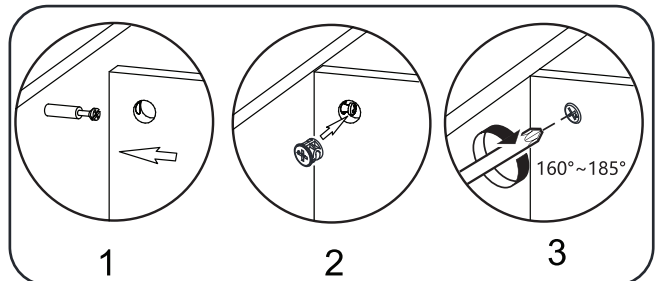
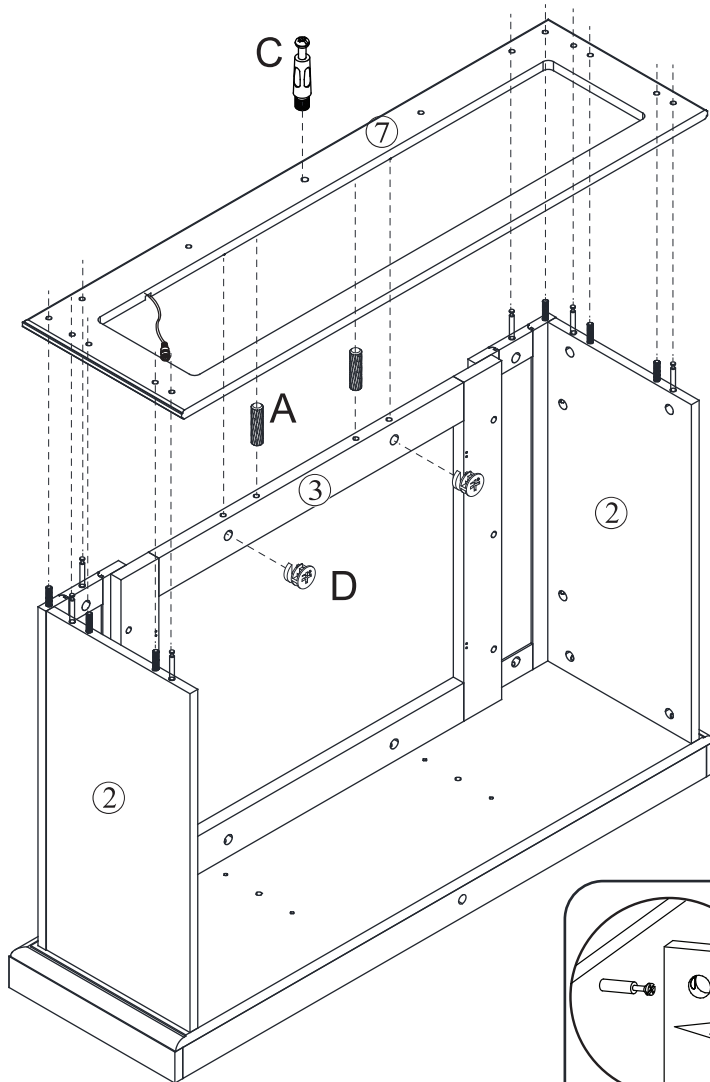
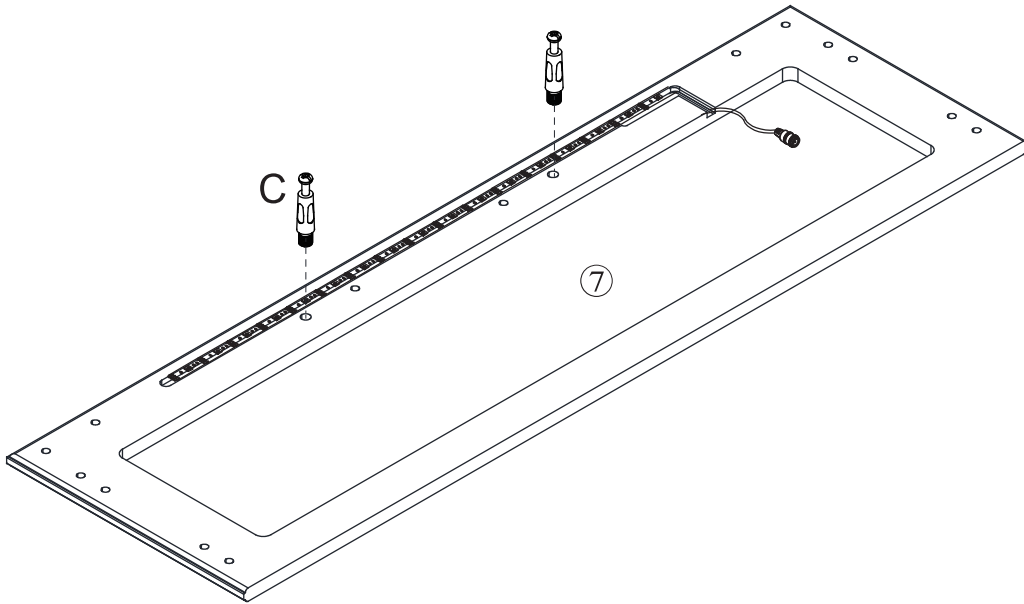

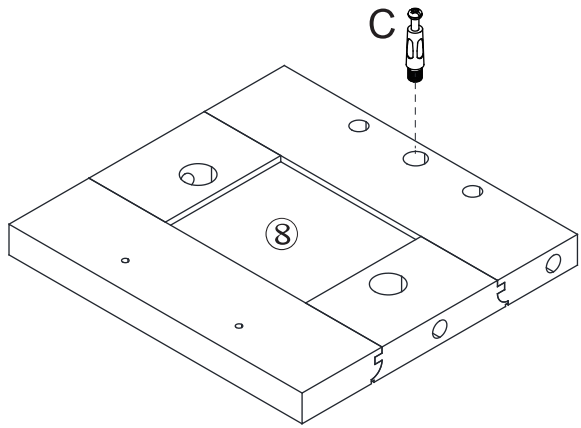

X2

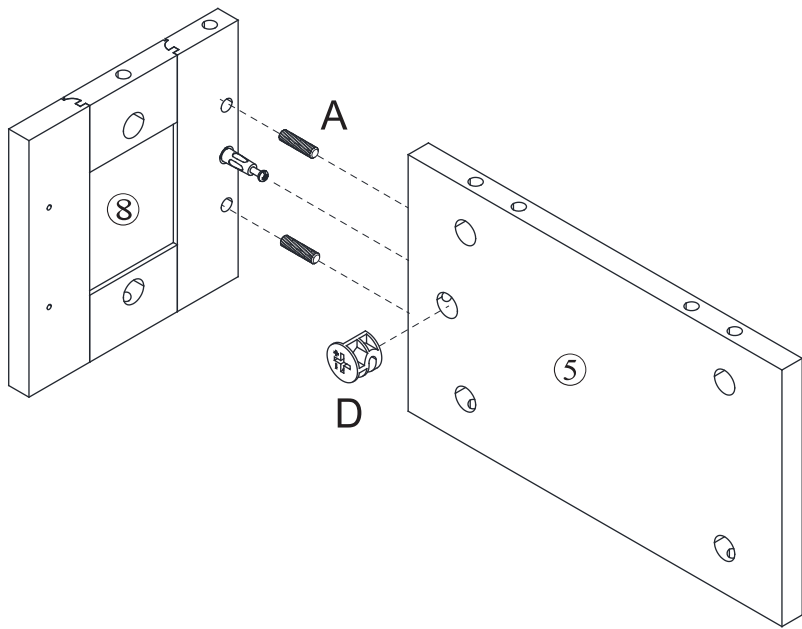

X2

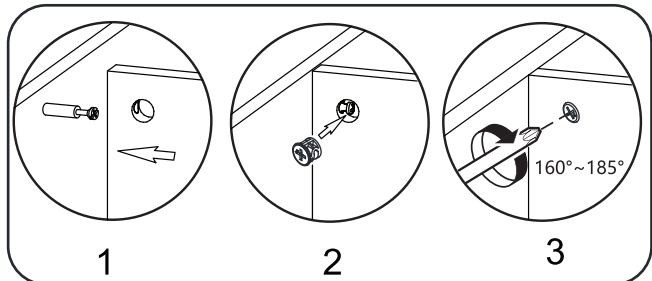



A x 2



D x 7

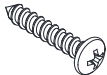

I x 4

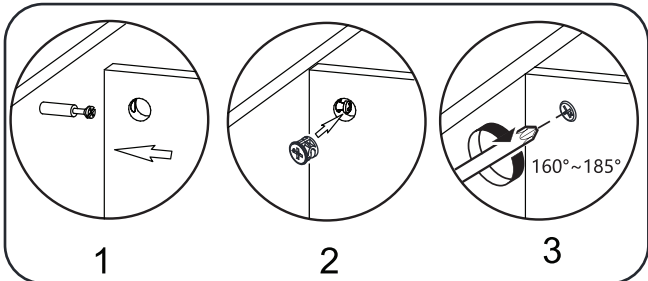
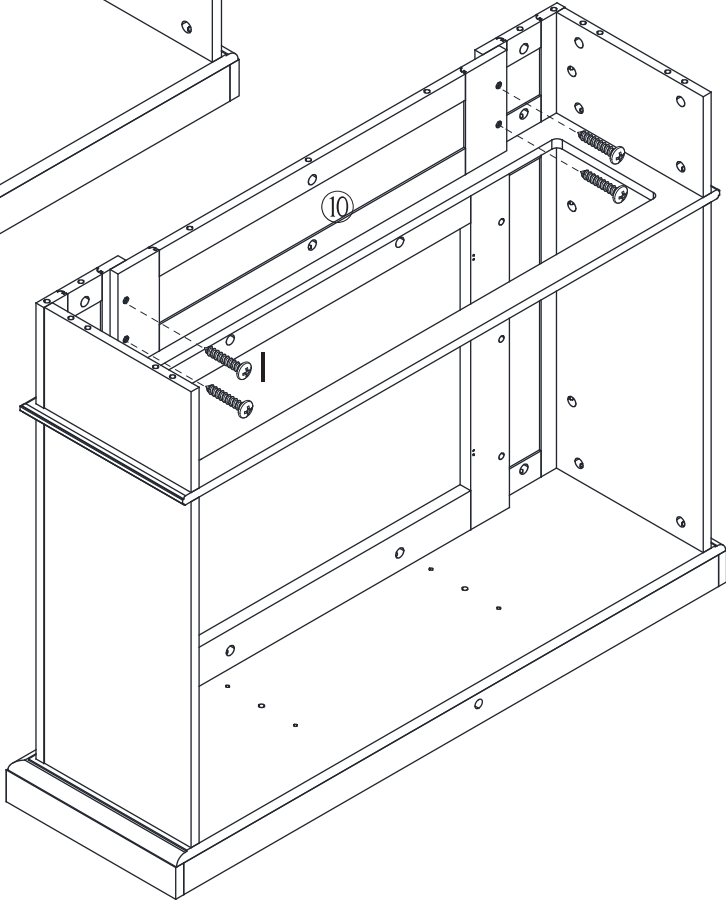
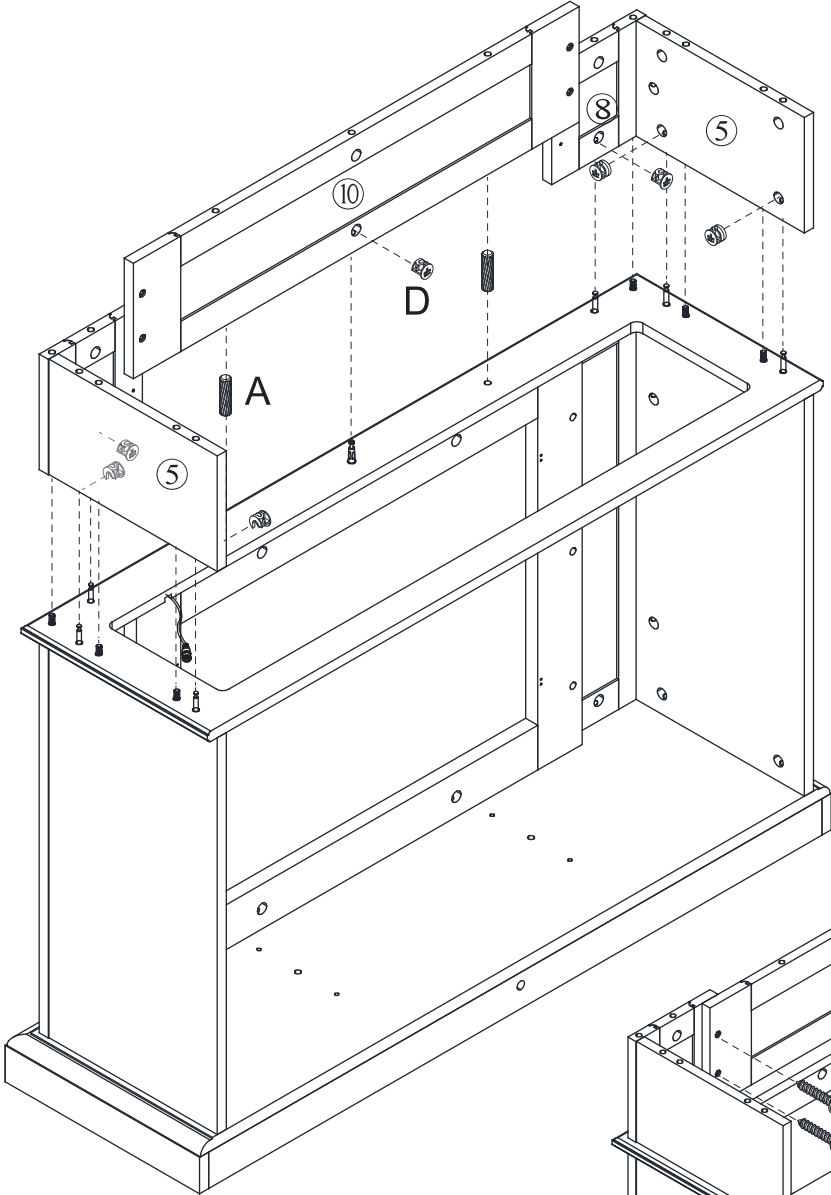



A x 8



C x 7



D x 7

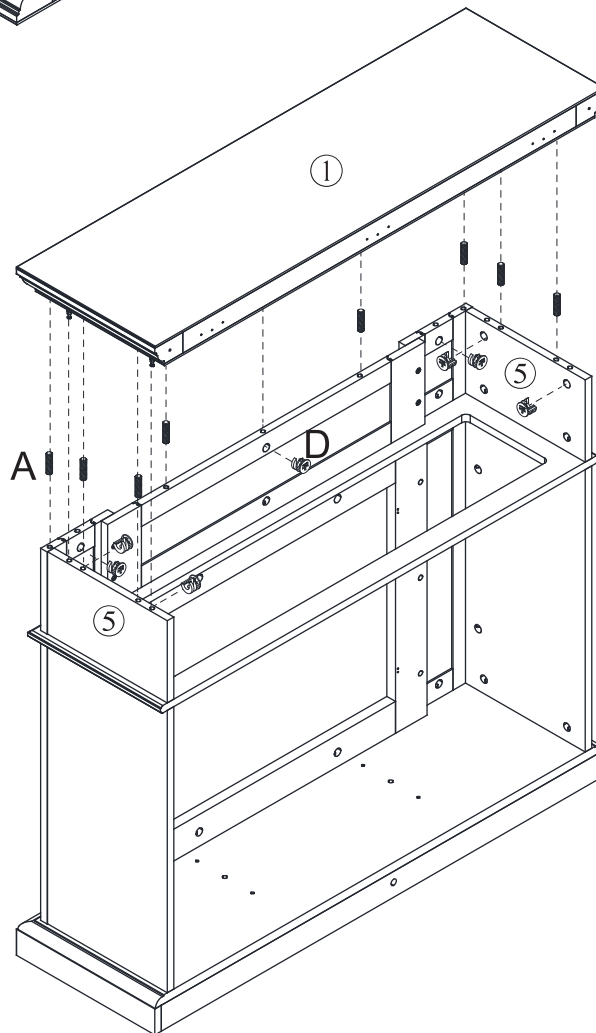
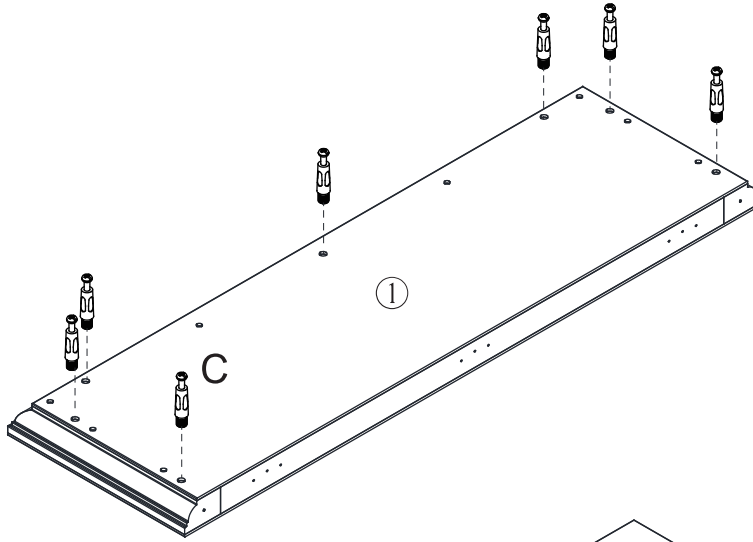



A x 4

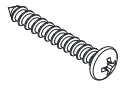

H x 8

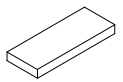

L x 10

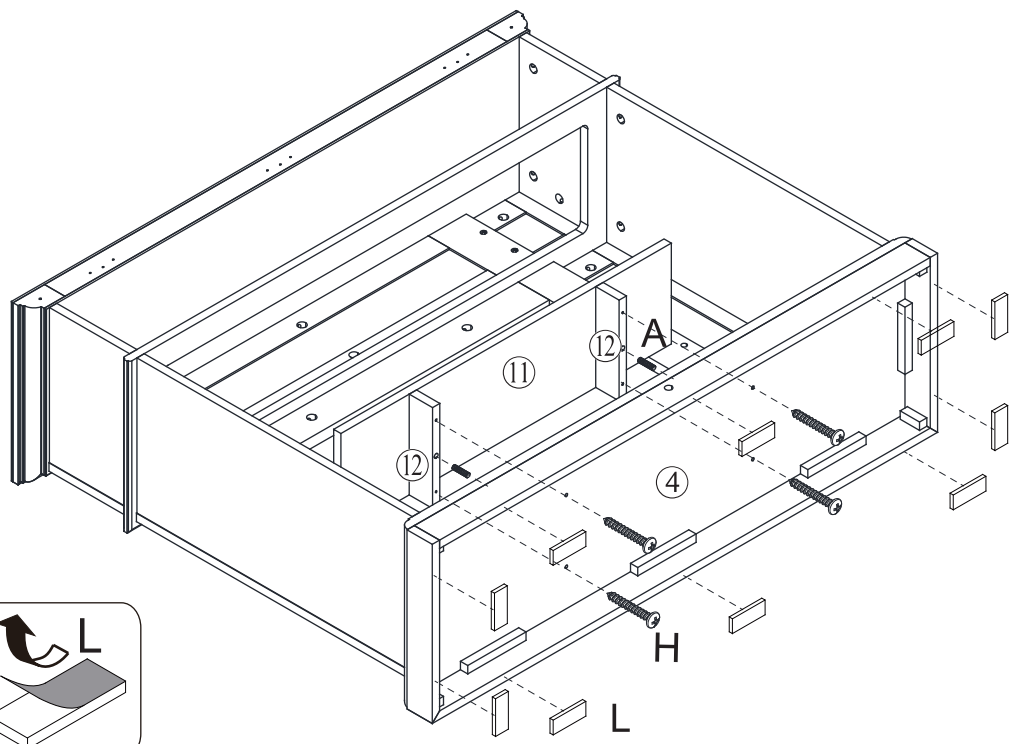
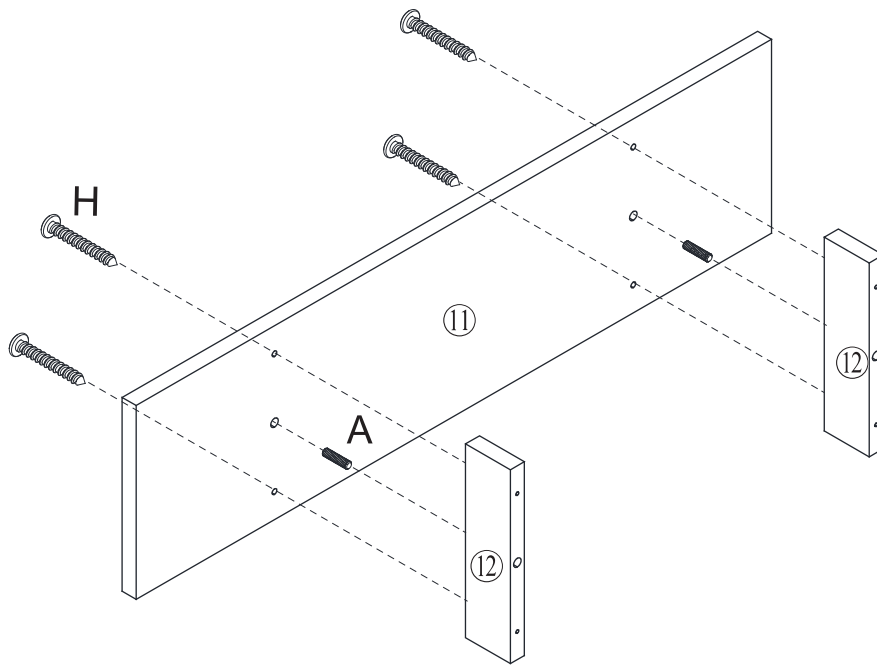

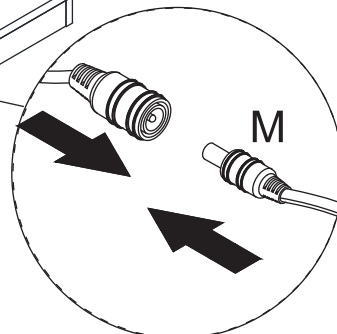
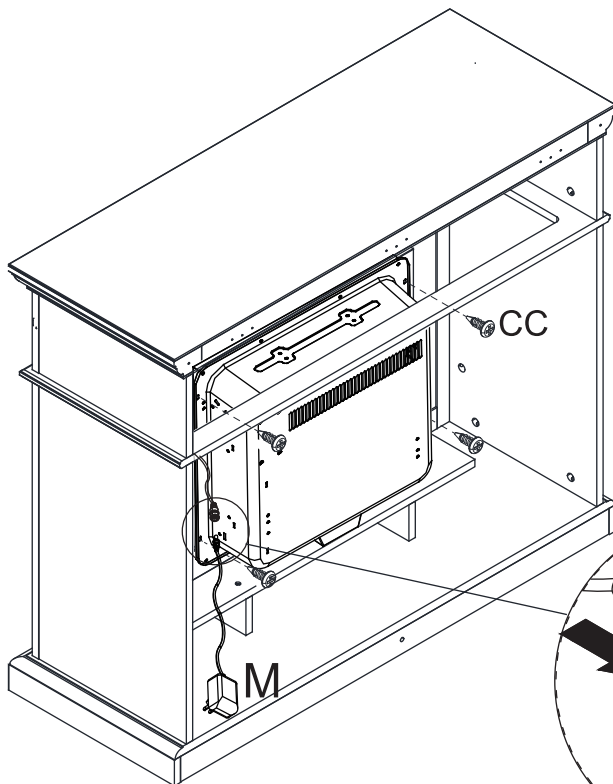
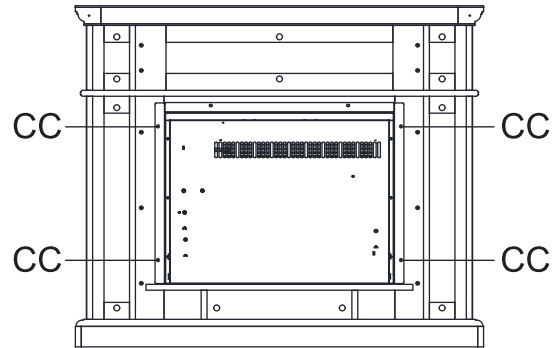
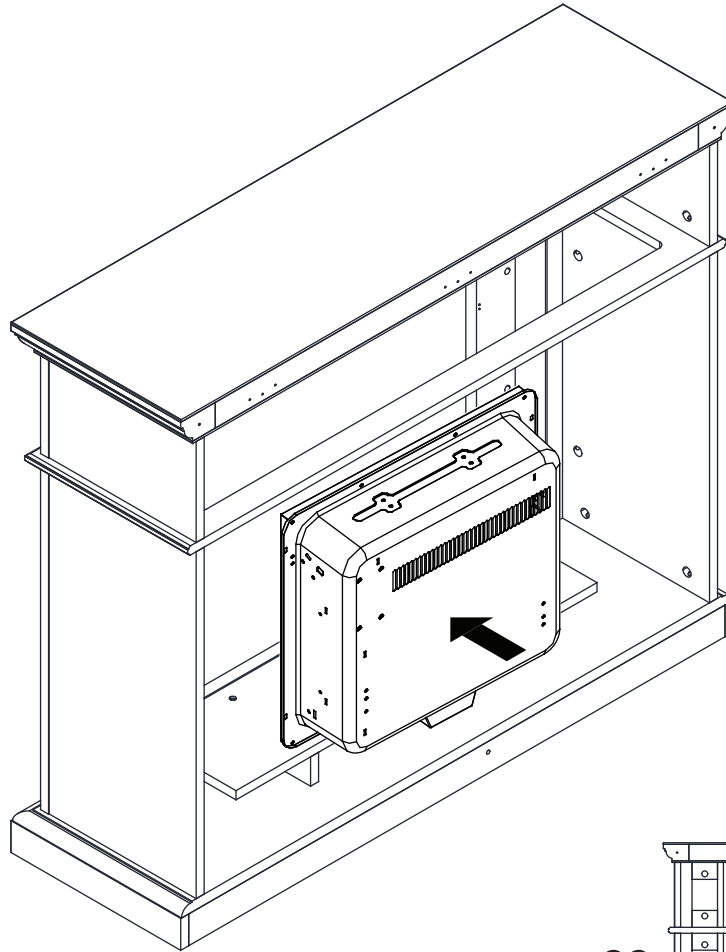
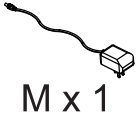



A x 1

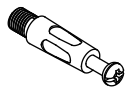

C x 2



D x 1

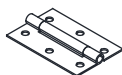

N x 3

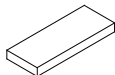

L x 1



O x 9

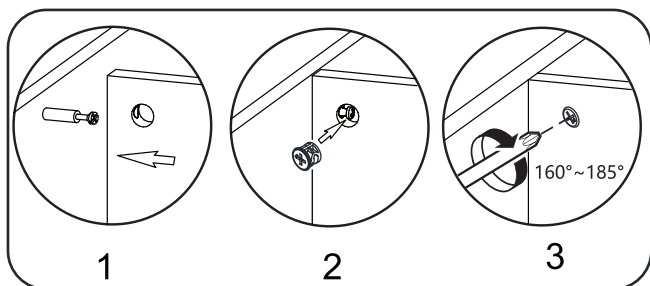
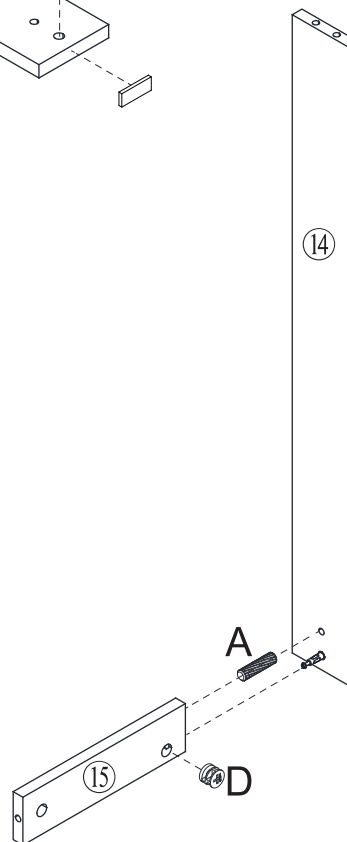
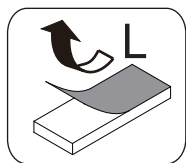
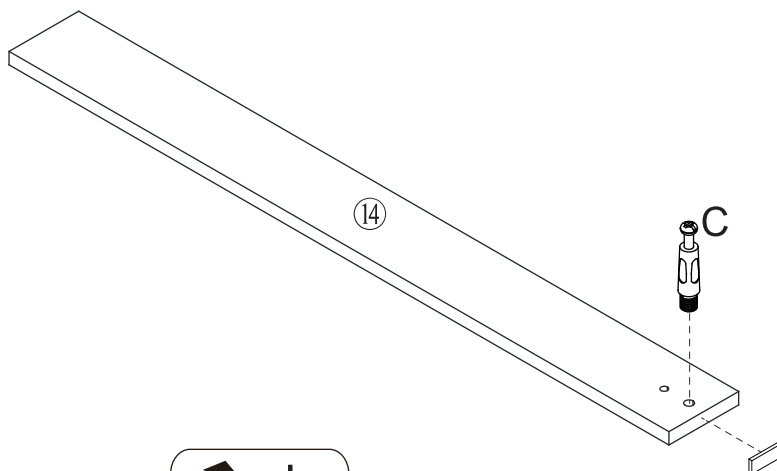
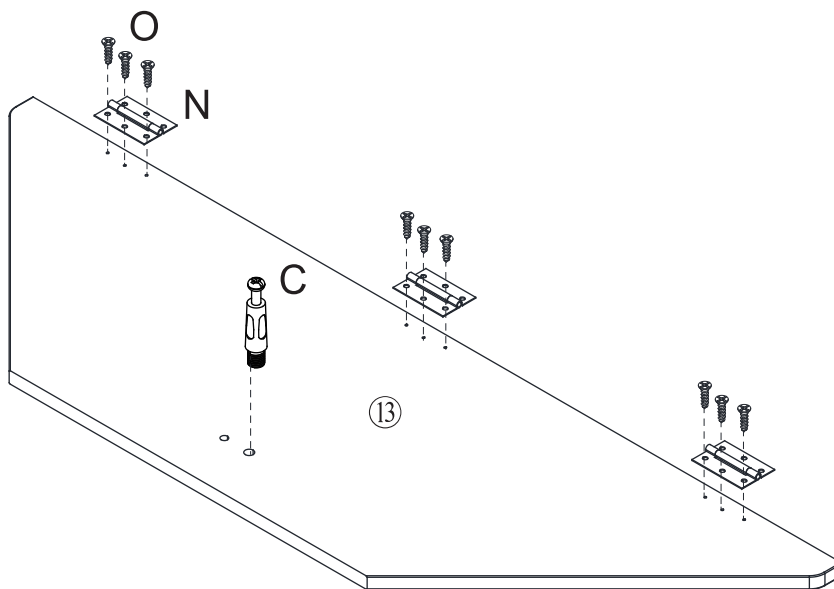



A x 1



C x 1



D x 2

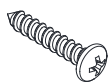

I x 2



J x 2



K x 2



O x 9

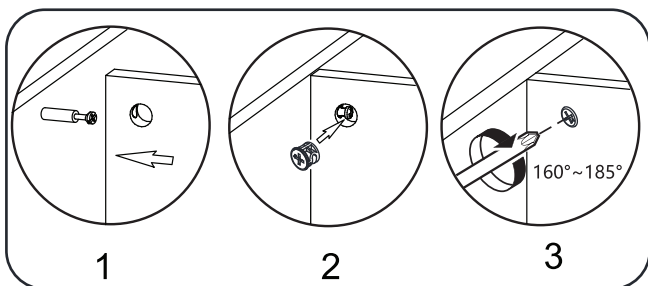
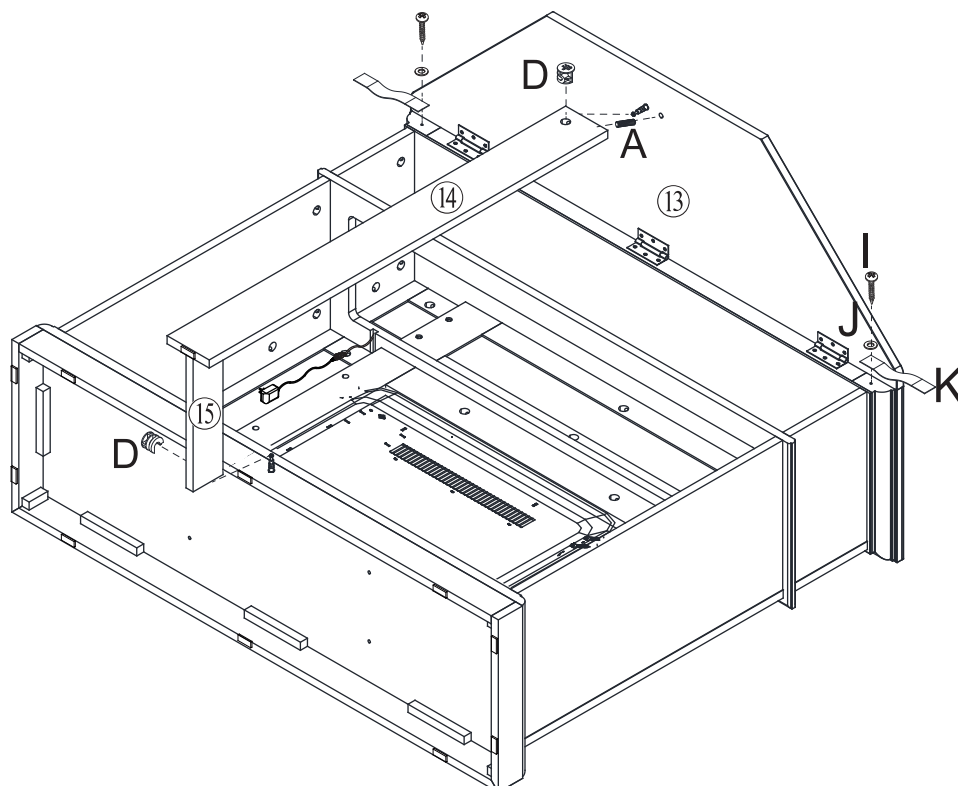
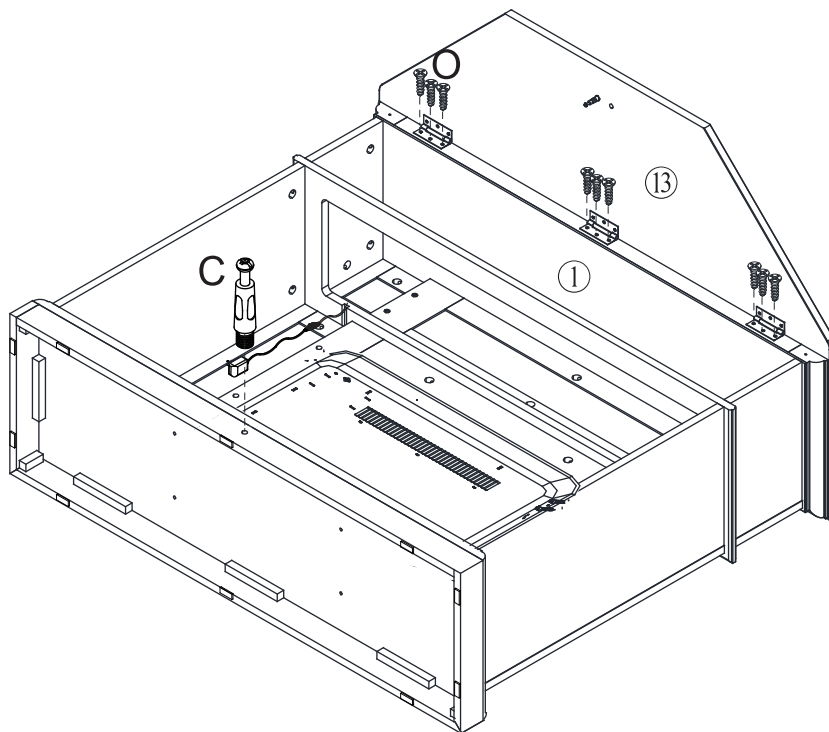

-  F x 2
-  G x 2
-  J x 2

